



Anti-Ligature Knob for L-Series Mortise Locks

The new anti-ligature knob from Schlage is designed for a natural grip, simple use and minimal gaps to impede apparent attachment points. When safety is just as critical as security you need door hardware that delivers reliable performance and durability. Available in a wide variety of L-Series lock functions, the anti-ligature knob is a versatile and smart solution.

Healthcare facilities and detention centers require door hardware that stands up to potentially abusive and high-use environments while also minimizing the risk of self harm. The Schlage anti-ligature knob is specifically designed for unique applications and challenges with these features.

- Tamper resistant design
- Easy-to-use Quad Grip styling
- Stainless steel construction
- Recessed knob and thumbturn
- Concealed mounting hardware
- ADA thumbturn with positive stop
- Flush mounted design
- Positive locking recessed set screws minimize unauthorized removal of trim
- Standard spindle blocking plate protects internal components in case of compromised knob
- Available in most L-Series lock functions



FEATURES

Meets or exceeds all ANSI Grade 1, A156.13 - 2005 Standards
 UL Listed, 3 hour fire-rated
 Door thickness : 1 3/4"
 Uses Standard L-Series Door Prep
 Available in 630 (32D) finish
 Antimicrobial coating option available on exposed trim

KNOB WITH CYLINDER TRIM



DIMENSIONS

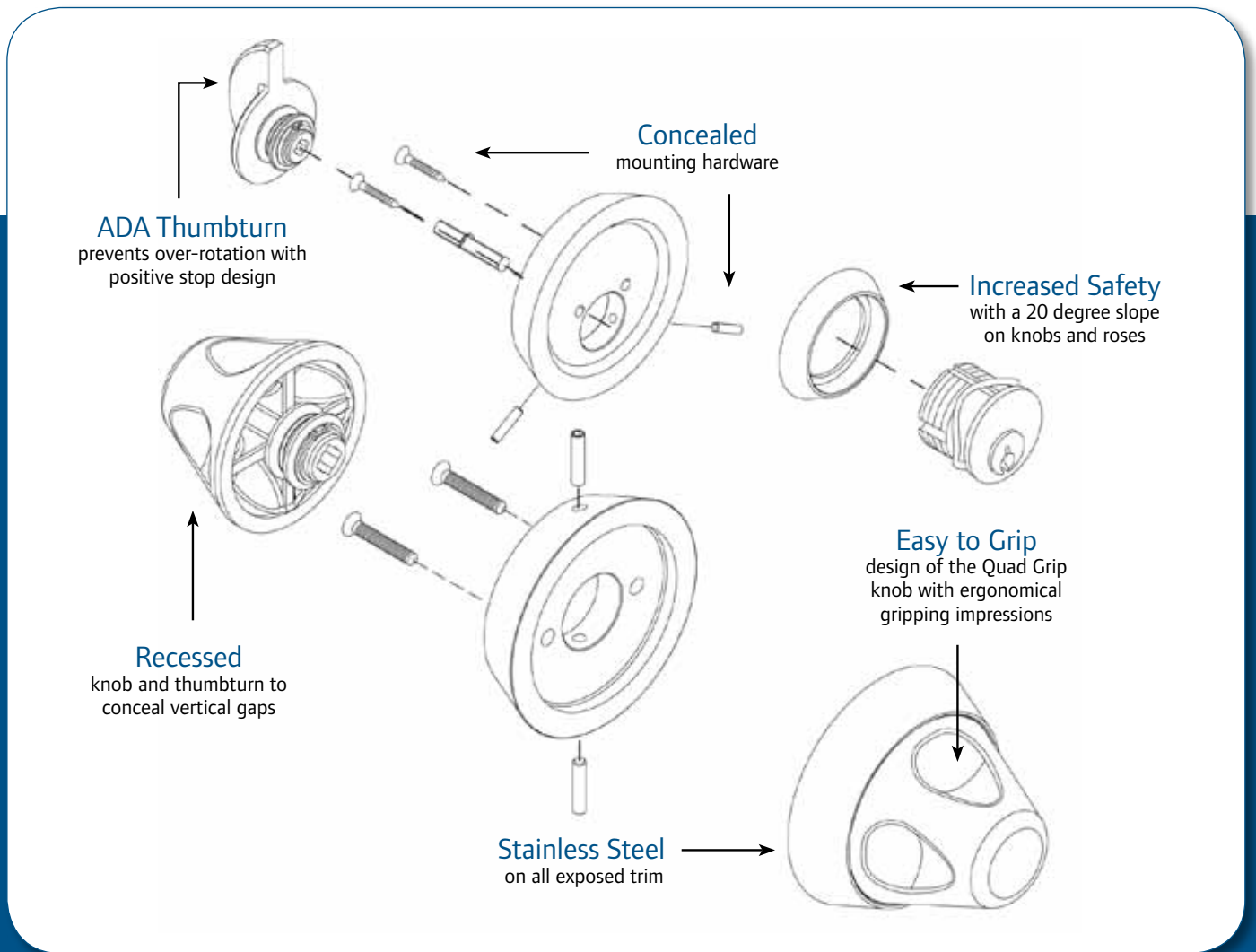
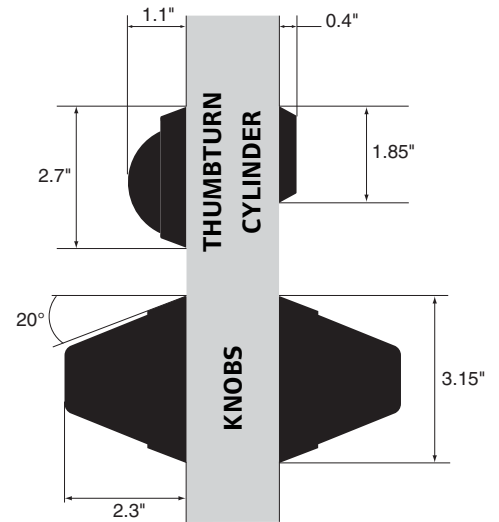

To find out more visit www.schlage.com or call 800-847-1864.

